

HYterm RB100



RB100 is a family of remote displays, suitable for all controllers manufactured by Hyterm. Equipped with 6 keys and a TFT graphic, led-backlight display with 320x340 pixel resolution.

MAIN FEATURES

Easy and intuitive

Thanks to the graphic interface created according to the best practices and available in several languages, it makes the customer experience easy and intuitive.

Quick and easy assembly

Designed for screw panel mounting, it offers quick and easy assembly and a high quality finishing.

Vandal Proof

Made with an anti-vandal design, the display is sealable and lockable on request.

Suitable for any environment

Made with a UV-resistant polycarbonate box with a high degree of protection, it is suitable even for the most severe indoor or outdoor installations; thanks to the optional knurled screws it can increase its degree of protection to IP67.

BENEFITS

- Usable in a wide variety of applications, from breeding to air conditioning through mechanics, chemistry and molding industry up to the most delicate applications such as clean rooms or datacenter.
- Thanks to the Plug & Play connection to the FC family controllers, it doesn't require any programming or initial parameterization.
- Can be customized for special applications.
- Simplifies man-machine interaction.
- FW upgradeable on site thanks to the built-in USB port.
- Made with quality components, it is guaranteed for 24 months.

RB100

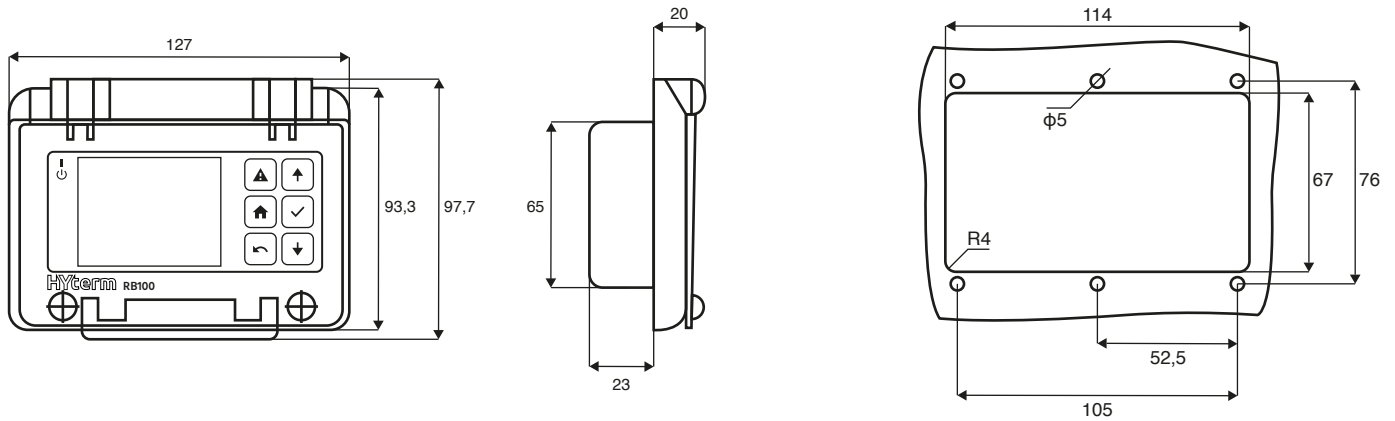

TECHNICAL DATA	Power supply	24Vac \pm 10% 50/60Hz 20 \div 32Vdc
	Power consumption	<3W
	Terminal block	Screw plug-in male/female connectors pitch 3,81 / 5,08
	Cable cross-section	min 0,5 mm ² \div max 2,5mm ² min 20 AWG Cu \div max 14 AWG Cu
OPERATING CONDITIONS	Operating temperature	-20 \div 50°C – Rh max 85% non-condensing
	Storage temperature	-20 \div 85°C – Rh max 85% non-condensing
	Vibrations	Vibrations <1g (9,8ms ²)
	Degree of protection	IP65, IP67 with knurled screw
	Degree of pollution	—
	Insulation class	—
CONN.	COM1	MODBUS RTU RS485 - Not optoisolated

MEASURE	Dimensions	127 \times 93,3 \times 43 mm
	Weight	
ENCLOSURE	Mounting	On panel
	Material	PC UV resistant
	Flammability Rating	V2 (according UL94)
	Outdoor suitability	F1 (according UL746C)
	Color	Gray RAL 7035
	Accessories	Knurled screws, key lock
STANDARD	Compliance	2014/30/UE (EMC– Electromagnetic compatibility)
	Technical Standard	EN 61000-6-1, EN 61000-6-2, EN 61000-6-3, EN 61000-6-4, EN 55014-1, EN 55014-2

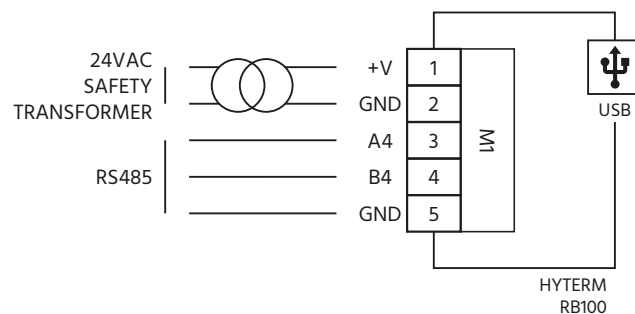

PRODUCT	DESCRIPTION	CODE
RB100	Remote interface 24Vac 50/60Hz IP65 RS485 not isolated	10.006.00.0000
RXXXX-C	Key lock kit	10.000.00.0002
RXXXX-V	Knurled screws kit	10.000.00.0003

Hyterm S.r.l.

Viale del lavoro, 18 - 25045 Castegnato (BS)
www.hyterm.com - info@hyterm.com

HYterm